



VX1

Now part of the DyeMansion Print-to-Product workflow

Enter the world of vapor smoothing

Compact design

Small footprint all-in-one unit.
Maximising space efficiency.

Smooth operation

Streamlined controls and intuitive to operate.
It's not just user-friendly; it's effortlessly intuitive.

Plug & play

No complex setups or technical know-how required.
Enjoy a hassle-free experience from day one.

Sustainable cartridge system

Reusable cartridge system designed to minimize waste
and cut costs.

Material diversity

Ready for powder bed based PA12, PA11 &
TPU materials.

Green and safe

Eco-friendly, FDA approved food-grade treatment agent.
For real peace of mind.

Technical Specifications

VX1 - Vapor Smoothing Machine

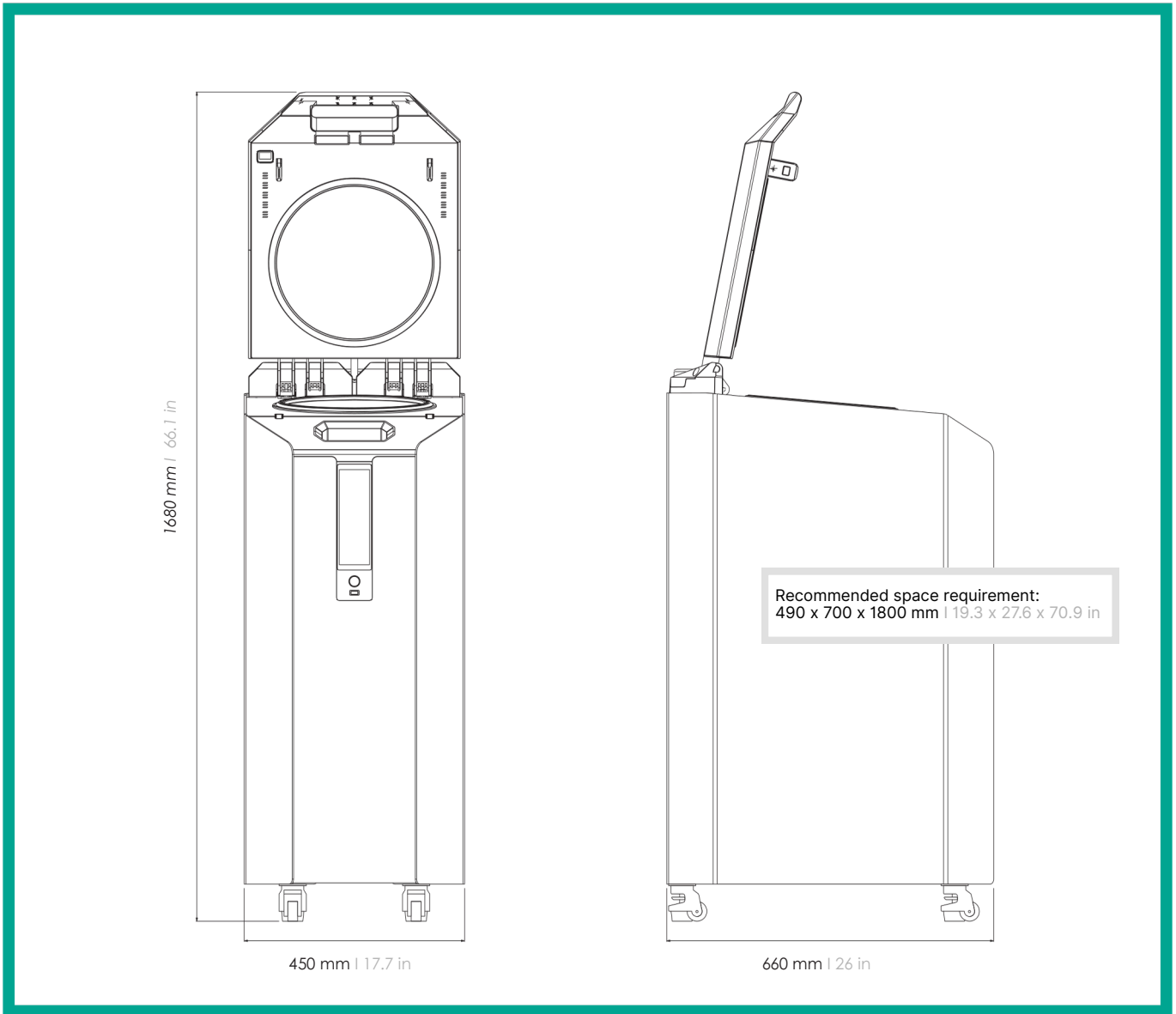

TECHNICAL DATA

Dimensions (W x D x H)	closed lid	450 x 660 x 1100 mm 17.7 x 26.0 x 43.3 in
	open lid	450 x 660 x 1680 mm 17.7 x 26.0 x 66.1 in
Process chamber volume (∅ x H)		280 x 400 mm (24.6 L) 11.0 x 15.7 in (1,501 in ³)
Cycle time		1.5 to 3 h
Power requirements EU US		230 V AC, 12 A, 50 Hz 208 V AC, 15 A, 60 Hz (dedicated circuit)
Energy consumption		less than 1 kWh per cycle
Compatible materials		PA12, PA11, TPU (see compatible materials datasheet)
Compatible printing processes		MJF, SLS, HSS, SAF
Treatment agent classification		pharmaceutical/food grade
Connectivity		EG25-G LTE Cat 4 Modem